



Ro-Flo Compressors

Biogas Applications



Biogas Applications



Organic Waste Digester



Wastewater Treatment



Options for Custom, Integrated Skid Designs

- Dehydration
- Up to 20% H₂S Concentration
- Noise Isolation
- Heaters
- PLC with HMI Interface

Superior Performance

- Highly Resilient & Versatile for multiple applications
- 24/7 operations
- Low maintenance requirements

Reliable. Efficient. Optimal Performance.

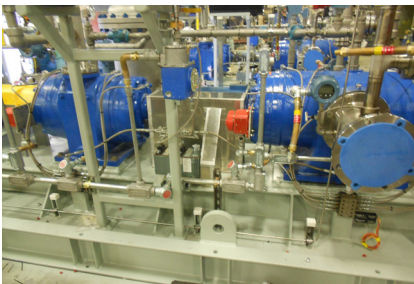

Equipment & Solutions

RoFlo Product Options

- ▶ Flow Rates 250 scfm to 700 scfm
- ▶ Ave. Inlet Pressure 0
- ▶ Ave. Outlet Pressure 20 to 70 psig
- ▶ Variable Frequency Drive
- ▶ Skid Enclosure

Other Biogas Equipment Available

- ▶ CO₂ Removal
- ▶ Dehydration
- ▶ Hydrogen Sulfide
- ▶ Blower Skids
- ▶ Water Pump Skids
- ▶ Instrument Air Skids
- ▶ Sales Gas Compressors

Manufacturing Capabilities & Expertise

- ▶ 125,000 sq. ft.
- ▶ Capacity / month ~10 to 20 skids
- ▶ 40+ years in Compression
- ▶ 20+ years in Renewable Natural Gas

Engineering & Fabrication Designed to Optimize Performance & Energy Usage with Minimal Consumables





Capacity Capabilities Performance Optimization.



Biogas Skid, Standard Module with Options

- Model type: Ro-Flo 11s vane compressor
- Capacity: 550 scfm normal capacity
- Pressure: 35 psig final pressure
- Temperature: 40F pressure dewpoint at skid exit
- Motor: 125 HP | 900 rpm
- Air Cooling: Compressor aftercooler + jacket water fluid cooler

Full enclosure + PLC Mounted

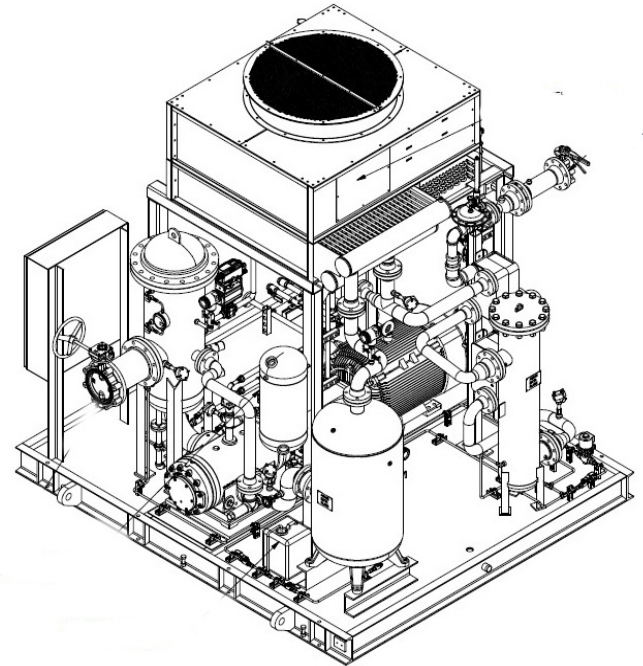

In-House Engineering, Design & Fabrication

